

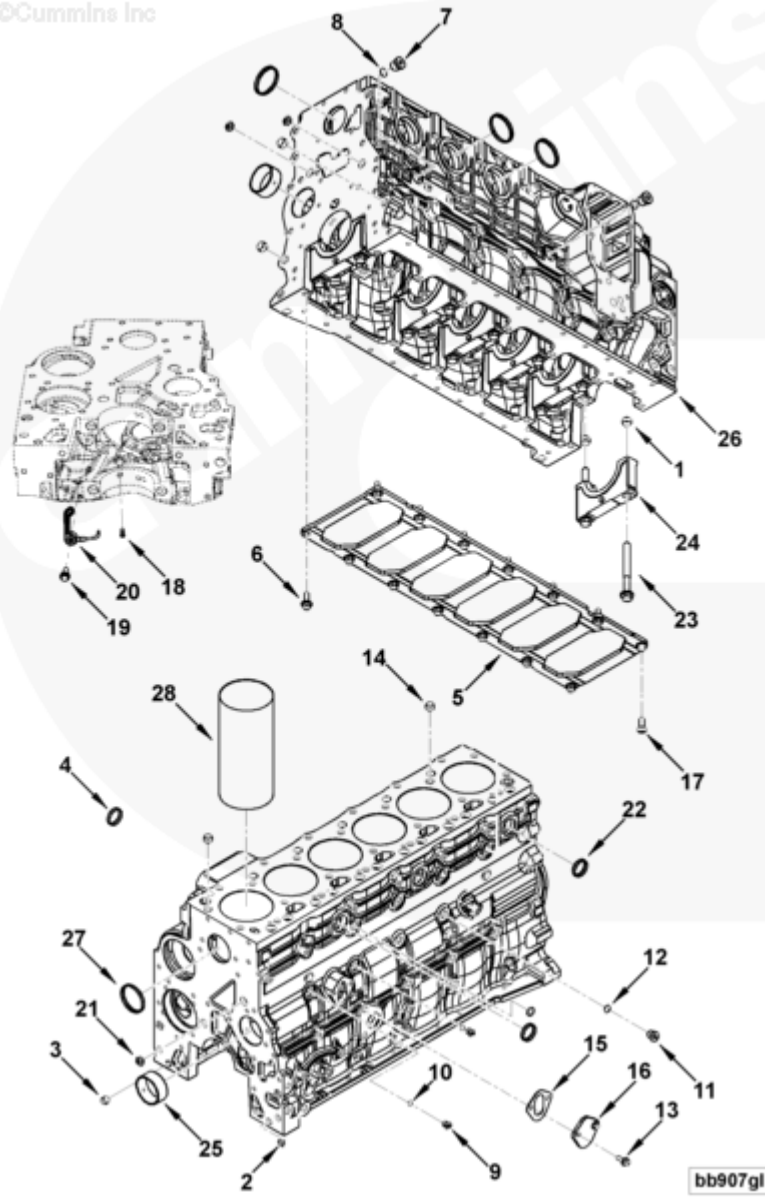

## Parts Catalog - Option Detail

Electronic Parts Catalog - Option Detail				
Option	Group	Graphic	Film Card	Date
BB9843-13	01.01	bb907gl	T	15-NOV-05
<b>Engines</b>	4B3.9, 6A3.4, 6B5.9, B GAS INTERNATIONAL CM556, B4.5, B4.5 CM2350 B129B, B4.5 CM2350 B146C, B4.5 CM2350 B147B, B4.5 RGT, B4.5S, B5.9 G, B5.9 GAS PLUS CM556, B5.9 LPG, B5.9 LPG PLUS CM556, B6.7 CM2350 B121B, B6.7 CM2350 B135B, B6.7 CM2350 B136C, B6.7 CM2350 B148B, B6.7 G CMOH6.0 B125, B6.7N CM2380 B150B, B6.7S, F3.8 CM2350 F120B, F3.8 CM2350 F128C, F3.8 CM2350 F132B, F3.8 F102, G3.9, G5.9, G5.9 CM558, ISB (CHRYSLER), ISB CM2150, ISB CM2150 E, ISB CM550, ISB CM850, ISB/ISD4.5 CM2150 B119, ISB/ISD4.5 CM2150 SN, ISB/ISD6.7 CM2150 B120, ISB/ISD6.7 CM2150 SN, ISB/ISD6.7 CM2880 B126, ISB3.9 CM2220 B107, ISB4.5 CM2150, ISB5.9G CM2180, ISB6.7 2010 DCX PICKUP, ISB6.7 2013 DCX CHASSIS CAB, ISB6.7 CM2150 SQ, ISB6.7 CM2250, ISB6.7 CM2350 B101, ISB6.7 CM2350 B103, ISB6.7 CM2350 B142, ISB6.7 CM2670 B153B, ISB6.7 G CM2180 B118, ISBE CM2150, ISBE CM800, ISBE2/ISBE3 CM850, ISBE4 CM850, ISD4.5 CM2150, ISD6.7 CM2880 D101, ISF2.8 CM2220, ISF2.8 CM2220 AN, ISF2.8 CM2220 EC, ISF2.8 CM2220 ECF2, ISF2.8 CM2220 F101, ISF2.8 CM2220 F117, ISF2.8 CM2220 F122, ISF2.8 CM2220 F126, ISF2.8 CM2220 F129, ISF2.8 CM2220 IAN, ISF3.8 CM2220, ISF3.8 CM2220 AN, ISF3.8 CM2220 F103, ISF3.8 CM2220 F110, ISF3.8 CM2220 F116, ISF3.8 CM2220 F134B, ISF3.8 CM2220 IAN, ISF3.8 CM2350 F109, ISF4.5 CM2220 F123, ISG11 CM2880 G106, ISG11 CM2880 G108, ISG12 CM2880 G107, ISG12 CM2880 G109, ISG12 G CMOH6.0 G111, QSB3.9 30 CM550, QSB3.9 CM2880 B138, QSB4.5 30 CM550, QSB4.5 CM2150 B108, QSB4.5 CM2250 B131, QSB4.5 CM2250 EC, QSB4.5 CM2350 B106, QSB4.5 CM2350 B122			



SMALL | MEDIUM | LARGE

Cart	Ref No	Part Number	Part Description	Required	Remarks
View My Cart					
		BB9843-13	Cylinder Block		<a href="#">Cylinder Block...(More)</a>
					Engine Family: "B" Series
					Cylinder: 6
					Aspiration: Charge Air
					Cooled, Turbocharged
					Turbocharger Exhaust Outlet
					Location:
					High Speed Balancer: No
					Restricted Customer: Chrysler

					Water Pump Location:
					Crank Gear Material:
					Fuel Type: Diesel
					Premium Block: No
					Tapped Fittings: Storm
					Structural Block: No
					Block Mounted Bedplate: Yes
					Oil Pan Flange Bolt Pattern:
					299 X 775.4
					Flywheel Housing Attachment
					Provision: Cylinder Block
					Front Engine Mount Pattern:
					320 mm Spread
					Gear Housing Drive Flange:
					None
					Restricted Fuel Pump
					Manufacturer/Model:
					Bosch Common Rail
					Non-Siamese Bore, Unpainted.
					Front Gear Drive.
<input type="checkbox"/>	1	<a href="#">3900068</a>	Ring Dowel	2	
<input type="checkbox"/>	2	<a href="#">3920706</a>	Expansion Plug	1	
<input type="checkbox"/>	3	<a href="#">3949326</a>	Ring Dowel	2	
<input type="checkbox"/>	4	<a href="#">3900958</a>	Expansion Plug	1	
<input type="checkbox"/>	5	<a href="#">3959073</a>	Cylinder Block Stiffener	1	
<input type="checkbox"/>	6	<a href="#">3902460</a>	Hexagon Flange Head Cap Screw	11	M10 X 1.50 X 25.
<input type="checkbox"/>		<a href="#">4089503</a>	Cylinder Block Kit	1	
		<a href="#">4089502</a>	Cylinder Block Hardware Kit	1	
<input type="checkbox"/>		<a href="#">3678873</a>	Threaded Plug	2	M18 X 1.5 X 19.5

	7	3678791	Threaded Plug	1	M18 X 1.5 X 19.5
<input type="checkbox"/>	8	3678786	O-Ring Seal	1	M18
<input type="checkbox"/>		3678923	Threaded Plug	2	M10 X 1.00 X 13.5
<input type="checkbox"/>	9	3678924	Threaded Plug	1	M10 X 1.00 X 13.5
<input type="checkbox"/>	10	3678925	O-Ring Seal	1	M10.
<input type="checkbox"/>		3680420	Threaded Plug	1	
	11	3680419	Threaded Plug	1	
<input type="checkbox"/>	12	3678912	O-Ring Seal	1	M14
<input type="checkbox"/>	13	3900630	Hexagon Flange Head Cap Screw	2	M8 X 1.25 X 20
<input type="checkbox"/>	14	3902343	Ring Dowel	2	
<input type="checkbox"/>	15	3939258	Cover Plate Gasket	1	
<input type="checkbox"/>	16	3948083	Cover Plate	1	
<input type="checkbox"/>	17	3949830	Round Head Cap Screw	1	M10 X 1.50 X 25
<input type="checkbox"/>	18	3959574	Piston Cooling Plug	6	
<input type="checkbox"/>	19	3964817	Banjo Connector Screw	6	
<input type="checkbox"/>	20	3968877	Piston Cooling Nozzle	6	
		3970793	Cylinder Block	1	Serviced as 4089503
<input type="checkbox"/>	21	3900956	Expansion Plug	3	17.73 mm
<input type="checkbox"/>	22	3905401	Expansion Plug	3	
<input type="checkbox"/>	23	3927948	Fracture Resistant Screw	14	
<input type="checkbox"/>		3974157	Main Bearing Cap	7	
<input type="checkbox"/>	1	3900068	Ring Dowel	2	
	24	3974156	Main Bearing Cap	1	
<input type="checkbox"/>	25	3940059	Bushing	2	
	26	3972843	Cylinder Block	1	
<input type="checkbox"/>	27	3975796	Expansion Plug	9	
<input type="checkbox"/>	28	3904166	Salvage Sleeve	A/R	

